

**CREATE YOUR OWN
MONSTER**
FRANKENSTEIN
Made with Pride **TRIKES** Plattsburgh, KS, U.S.A.

Installation Guide

Yamaha Bolt

36" Light Sport 200 Trike Kit

All Years



INCLUDED IN YOUR TRIKE KIT:

COMPONENTS

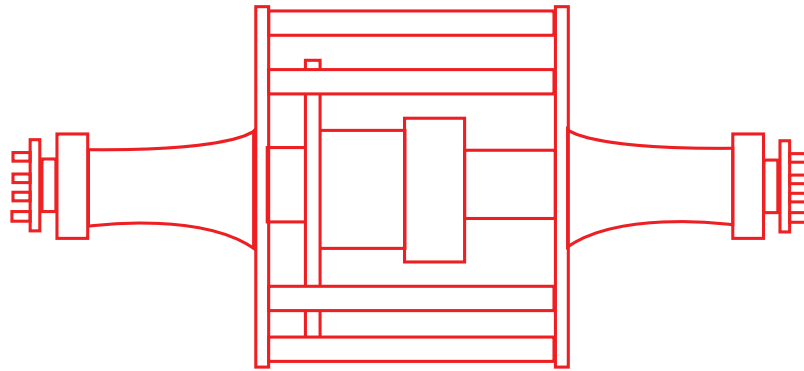

Frankenstein Trikes Rear End

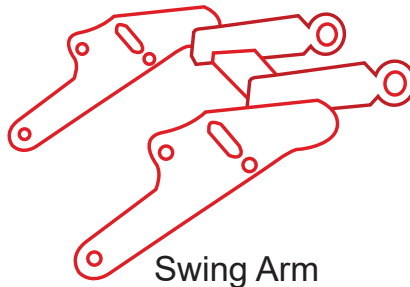

Swing Arm

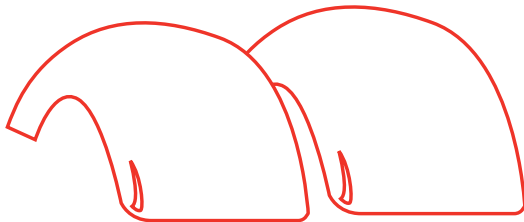

2 Fenders

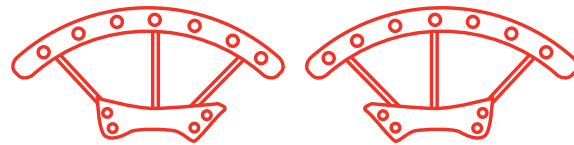

2 Fender Brackets

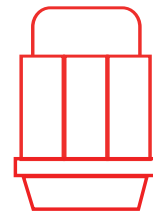
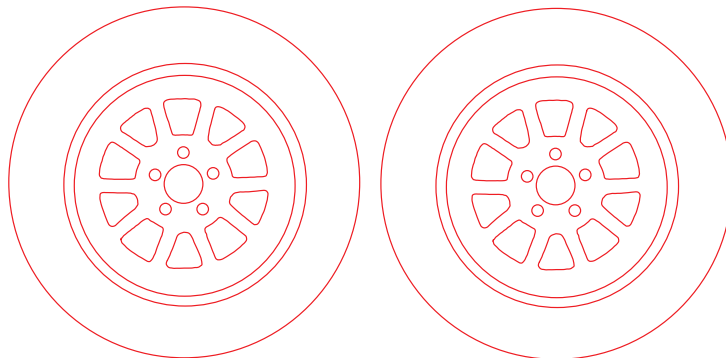

10 lug nuts

- 2 Race Star 15" X 8" wheels style FST-10-580146-BMF
1 2 Center caps and 2 General Altimax 215/60R15 tires

HARDWARE

PULLEY MOUNTING

5 pcs. - 7/16" - 14 x 1 1/2" Grd. 8 (Gold) Hex Head Bolt

5 pcs. - 7/16" Lock Washer

FENDER MOUNTING

14 pcs. - 3/8" - 16 x 1" Grd. 5 (Zinc) Hex Head Bolt

14 pcs. - 3/8" I.D. 1" O.D. 1/16" Thick Grd. 5 Washer

14 pcs. - 3/8" -16 Nylock Nut

***NOTE!** Additional hardware used to mount fender brackets to the rear end are pre-installed onto the rear end.*

SHOCK MOUNTING

2 - M10 x 1.25 mm x 100 mm Hex Head Bolt (Upper Shock Mount)

2- M10 Flat Washer (Upper Shock Mount)

2 - M8 x 1.25 mm x 16 mm Button Head bolt with factory washer (Upper Shock Mount)

2 - 5/16" x 18 x 1 3/4"- Grd. 5 Hex Head Bolt (Lower Shock Mount)

2 - 5/16" Flat Washer Grd. 8 (Lower Shock Mount)

WHEEL MOUNTING

10 - Lug Nuts

BELT GUARD

2 - 5/16"-18 x 1 3/4" Grd. 5 Hex Head Bolt

2 - 5/16" - 18 Nylock nuts

2 - 5/16" x 7/8" x 3/8" Zinc Spacers

MUFFLER

2 - M10 x 1.25 mm x 16 mm Hex Head Bolt

2 - M10 Lock Washer

TOOLS

T40 Tamper Proof Bit



LOCTITE is included with every kit and must be used where instructed in this manual. **2**

STAGE 1. Motorcycle Preparation:

 **Always refer to your Yamaha owners manual before performing any work on your bike.**

1. Secure front wheel so motorcycle won't tip, set jack under the motorcycle and raise the jack to take the weight off of the rear wheel.

 **Factory exhaust will be too long for your Frankenstein Trike Kit.**

2. Remove muffler. If you have short exhaust you can leave them attached.

3. Remove upper and lower belt guards.

4. Loosen axle adjusters on both sides.



5. Remove axle nut.

6. Remove axle from wheel and swing arm.

7. Slide the belt off of the pulley.

3



Now would be a good time to check the condition of your pulley and belt.

Shown - Bolt your bike may vary depending on the year

8. Remove the banjo bolt from caliper



TIP Once the brake line is unhooked from caliper, make sure to hang line upright so no fluid leaks out and no air gets trapped in the brake line.



9. Remove shock with supplied bit.



10. Remove swing arm pivot shaft
Remove swing arm.



STAGE 2. Rear End Preparation/Installation:

★ 38" and longer rear ends are shipped with one or both axles not installed in the rear end. To install axles, remove the axle retainer plate (see diagram 11 pg. 8) and insert axle. Reinstall bolts, loctite and torque to 31 ft. lbs.

1. With swing arm and rear wheel removed, have a friend help set a wheel and tire on the brake side of the rear end. Install with lug nuts.

TIP Install center cap into wheel before mounting.

2. Set the rear end on the wheel that was previously installed. Remove the five bolts to the spokes, Remove axle, axle housing and star plate as a unit.



Do not remove green tape, it will be used as a reference point in the following instructions.



3. If your pulley or sprocket has a center hole with a diameter of approximately 1.980" (50.292mm) then your pulley or sprocket will need to be machined. Install tool as shown using supplied bolts. Place back side of tool onto lathe chuck. Use boring tool to expand the diameter of the center hole. Measure frequently while boring until the diameter of the center hole is 2.212" (56.185mm).

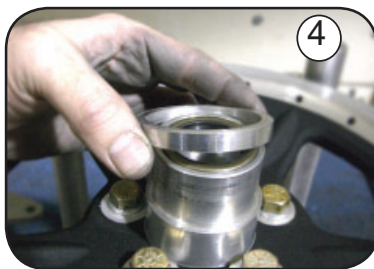

LOCTITE

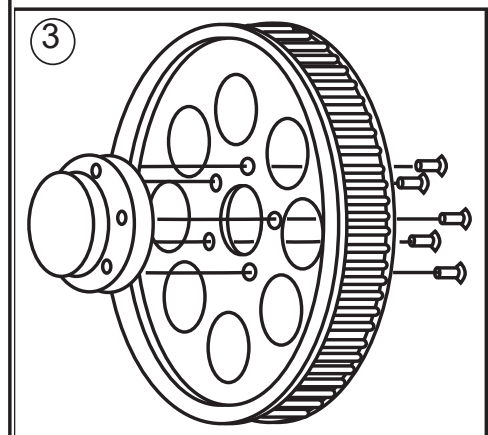
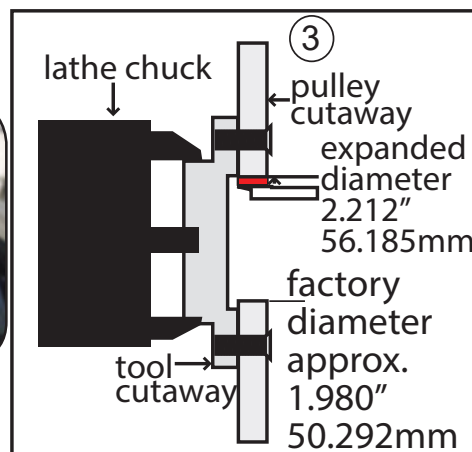

4. Install Pulley. Install 7/16" pulley bolts with lock washers provided apply **red loctite** and torque the pulley bolts. Have friend help hold the center section of the rear end with a screw driver through a hole in the rotor through one of the holes in the star plate. Torque the pulley bolts to 65 ft. lbs. Install belt over pulley as shown, the belt should be inside of all spokes
- 5 except the one that is marked with the green tape.



5. Install star plate. Install wheel and tire on drive side of rear end. Install with Lug-nuts.

TIP Install center cap into wheel before mounting.



6. Install swing arm on rear end. Refer to Diagram on page 7 for placement of washers and spacer.



7. Roll the Rear end and swing arm under the bike. Make sure spacer is in the bearing on both sides of swing arm. Install shaft and torque to factory specifications.

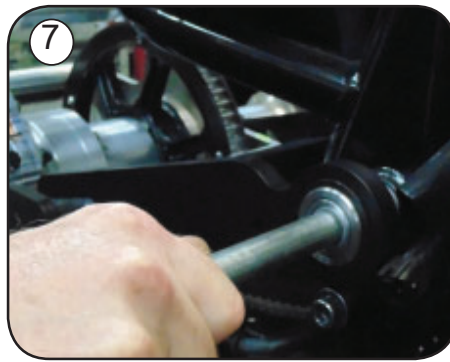

8. Install belt over transmission pulley and install cover.

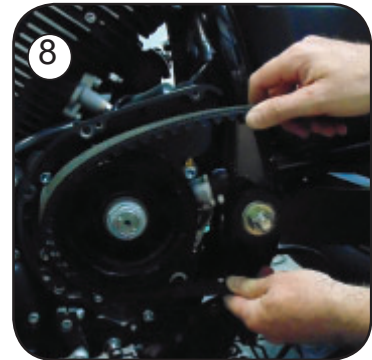

9. Install upper shock mount with supplied hardware.



10. Install shock that was removed from right side of bike onto left side of trike. Install shock that was removed from left side of bike onto right side of trike. Cylinder needs to face forward. You may need to raise or lower bike to line up shock on both mounts.

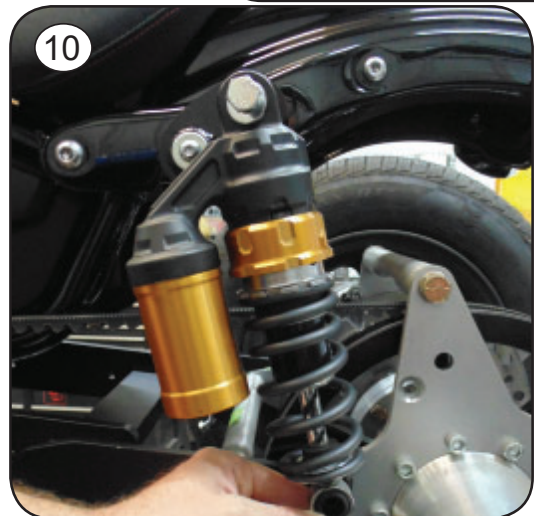

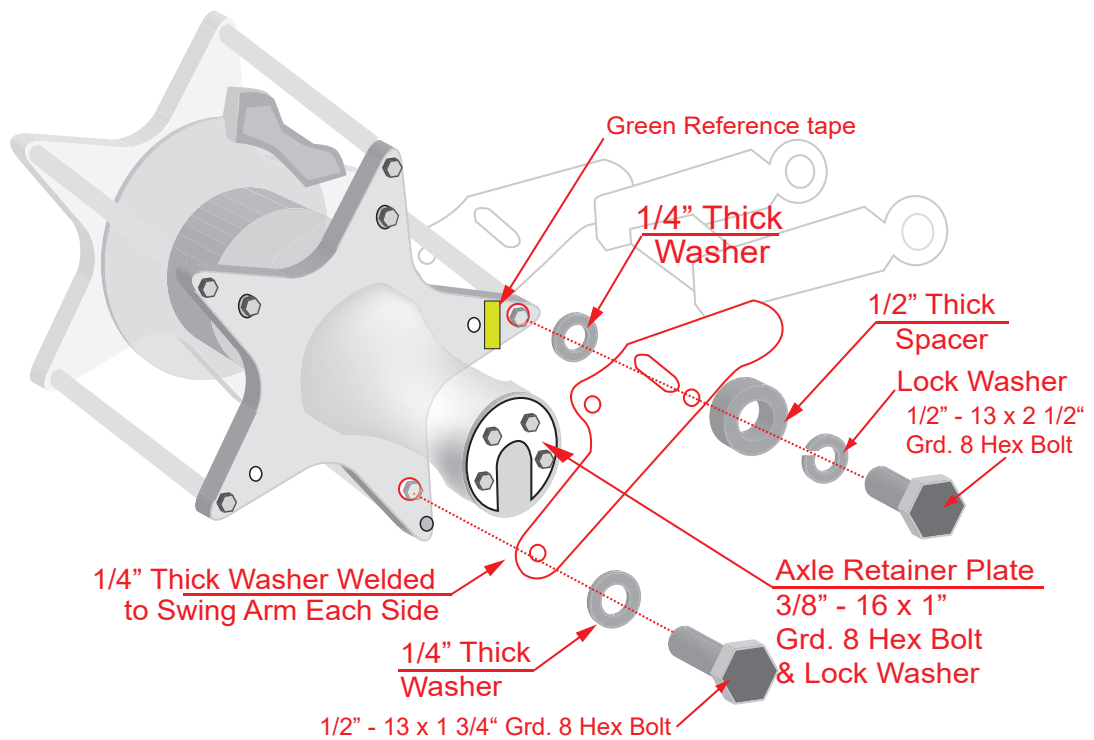
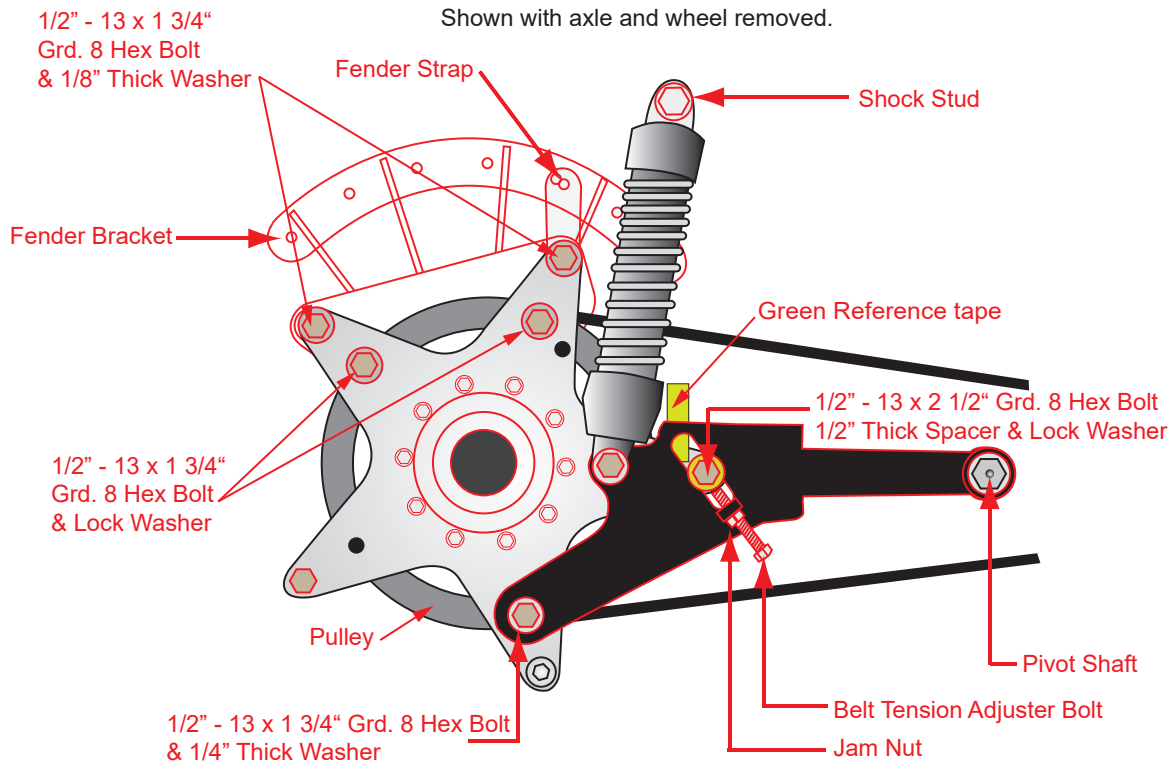

11. Attach fender brackets to fenders using supplied FENDER MOUNTING HARDWARE ★ *Note: side with more space from bolt holes to edge of fender goes toward the front.*

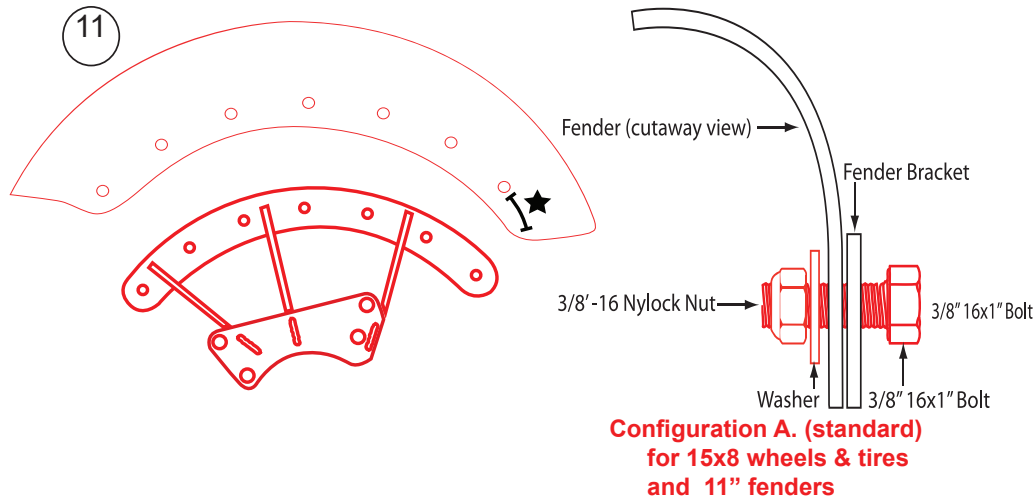

shown: left bracket and fender

12. Remove top two star plate to spoke bolts and two bolts just below bolts previously removed, on one side at a time. Install fender and bracket on the rear end. Apply blue loctite. Install top two star plate bolts. Install lower mounting bolts on fender bracket. Install fender and fender bracket on other side as previously described. Torque upper fender bracket bolts to 60 ft. lbs. Torque lower fender bracket bolts to 60 ft. lbs.

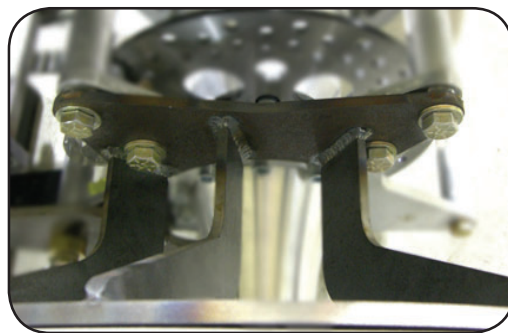

13. We have included a strap to reduce vibration. Please install the strap on both fender brackets as shown in this illustration. *(please note this is only used on kits with 15x8 wheels with 215/60/15 tires)*

14. Install strap in the third bolt position from the front. Use Loctite on bolt to secure gold thin nylock nut. Thick side of strap attaches to the star plate on the rear end, narrow end of strap attaches to fender.

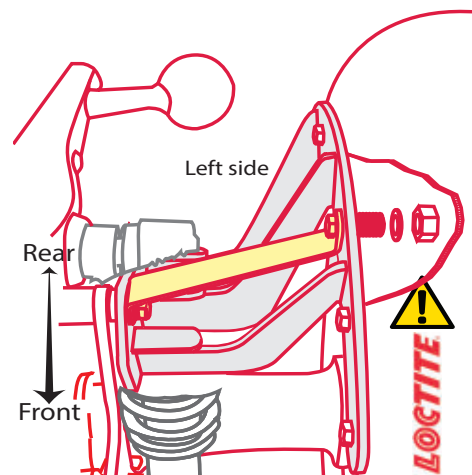

 *The trike must be sitting on the ground on its suspension to adjust the belt.*

15. Adjust belt tension to factory specs. Tighten jam nut on adjuster bolts.



16. Torque the four rear end mounting bolts to 60 ft. lbs.

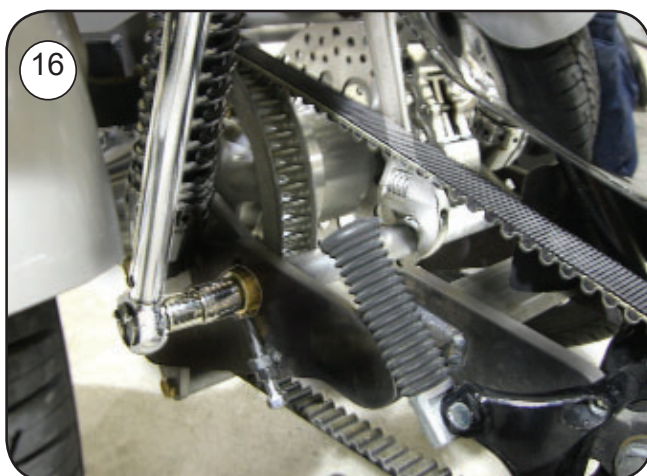

 **LOCTITE**

17. Hook up stock brake line, bleed rear brake, tighten lug nuts on rear wheels torque 78 to 85 ft. lbs. and go for a ride. Re-torque lug nuts after 25 miles or 100 mile maximum.

Tip: Recommended tire pressure is 25psi.



Note: Initially the brake and rotor need to be worn in before maximum braking can be achieved. Please use caution.

18. Install belt guard on left side of swing arm.

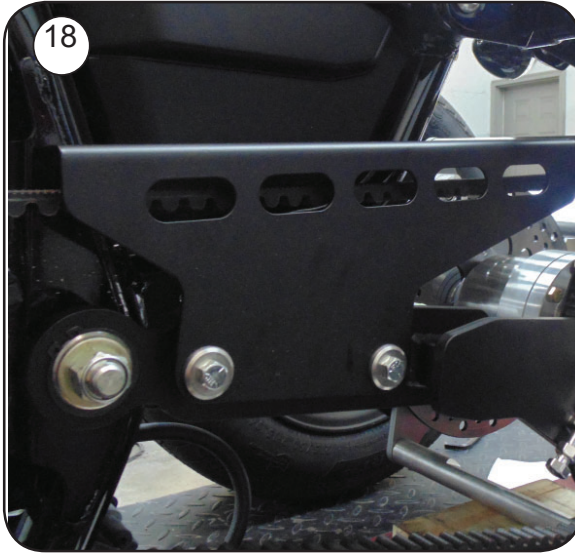

19. Install Exhaust bracket. Tighten bolts using factory bolt.

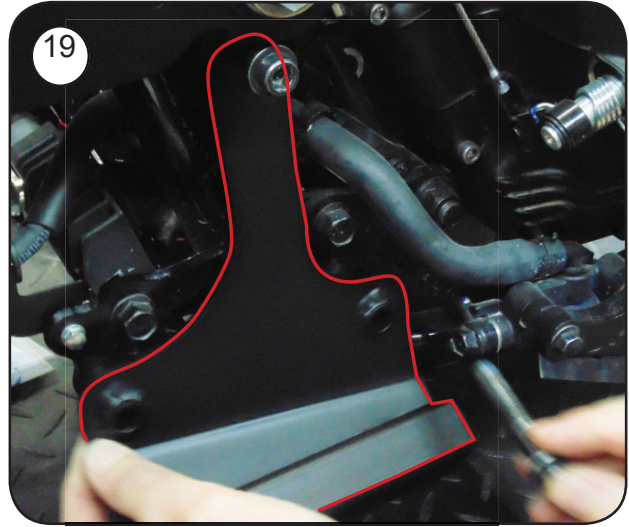

20. Install Exhaust "S" bend. Use new exhaust clamp on front leave loose.



21. Install muffler use factory exhaust clamp leave loose. Tighten muffler bounting bolts first to help align S-Bend tighten exhaust clamps last.



Our Trike rear ends are made from all 6061 T6 billet aluminum, except for our Light Sport Std. Trike rear end, which has 3/8" thick steel star plates, powder coated silver, instead of 1" thick billet aluminum star plates that we use on all our other Trike rear ends.

All of our rear ends have a Dana 30 differential, packed with Moly EP grease. 9" Ford street/strip axles with a bolt pattern of 5 studs on 4 1/2" bolt circle, wheel studs are 1/2" - 20. HHI/Frankenstein 4 piston billet caliper, 11 1/2" stainless steel brake rotor, or optional outboard Brakes with two HHI/Frankenstein 4 piston billet calipers and two 11" stainless steel brake rotors. We only use top quality new parts in our manufacturing of "Frankenstein Trikes" rear ends.

Replacement Parts

Differential seal: National oil seal # 481213 \$3.50 each

Differential Bearing: # 62102RS \$15.00 each

Axle Bearing: BCA # RW207-CCRA \$55.00 each

Brake Pads: HHI-101-001 \$30.00 pair

prices subject to change

